

# HIGH-POWER 3,500 BALL SCREW JACK OWNER'S INSTRUCTIONS (P/N 27452)

H&H Engineering "HIGH POWER" ball screw Jack is designed to lift up to 3,500 pounds a full 18". It's design also includes a silent shut-off by use of limit switches, a built in leveling device, attached foot plate and an emergency crank. An important part of owning and using High-Power Jack is being sure it is properly installed and serviced.

## GENERAL SAFETY:

Read and understand the Jack installation instructions. Always block trailer wheels when using the jack. Remove jewelry (watches, rings, etc.)

## BEFORE INSTALLATION:

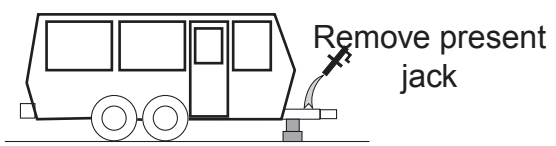

Raise your travel trailer's front end and place blocks or stabilizing jacks under the front "A" frame. Lower the trailer until it rests securely on stabilizing jacks or blocks. Retract present jack and remove.

## INSTALLATION:

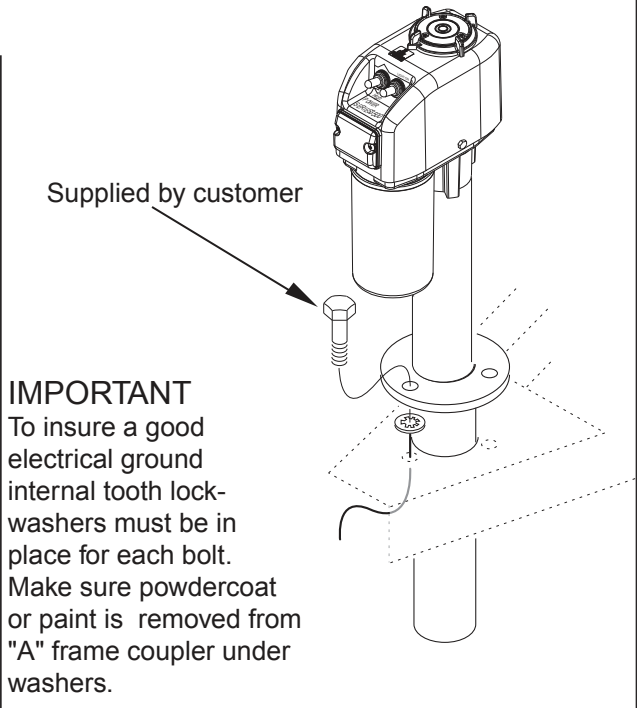
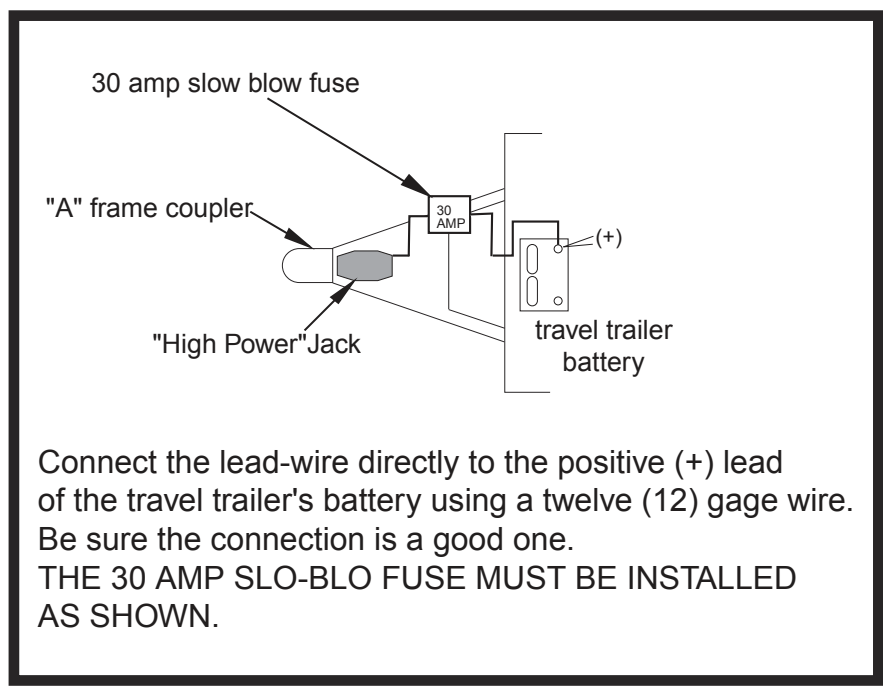

## IMPORTANT NOTICE:

If it is necessary to change the position of the powerhead relative to the post and flange (in order to provide clearance between powerhead and LP gas bottle or LP gas cover, or more clearance between the lift gate and the powerhead) loosen set screws and rotate head without lifting off coupling. Retighten set screws when head is in desired position. Lifting the unit off the post will make it necessary to re-synchronize timing between head and post. (SEE PAGE 5)

PAGE: 1 OF 5	DATE: 8 DEC 06	FORM #: 27743
REV . LETTER: L	ECN#: 13200	APPR OVED:

# HIGH POWER 3,500 BALL SCREW JACK OWNER'S INSTRUCTIONS

## INITIAL SET-UP AND HOW TO USE YOUR HIGH-POWER JACK LEVEL:

1. Install your HIGH-POWER Jack (SEE INSTALLATION PAGE 1).
2. Place a small level inside your RV on a surface you want to level. This might be a counter top or freezer compartment of a refrigerator.

NOTE: It will be necessary to move this level to check side to side and front to back condition.

3. Check the "inside level", level your trailer from side to side with stabilizing jacks or boards under the wheels.
4. Checking the "inside level", level your trailer front to back using your HIGH POWER JACK.
5. Carefully adjust the 3 stainless steel screws on the ring that surround the built in bulls-eye level (see picture) until the air bubble is inside the middle circle, it will then be leveled.

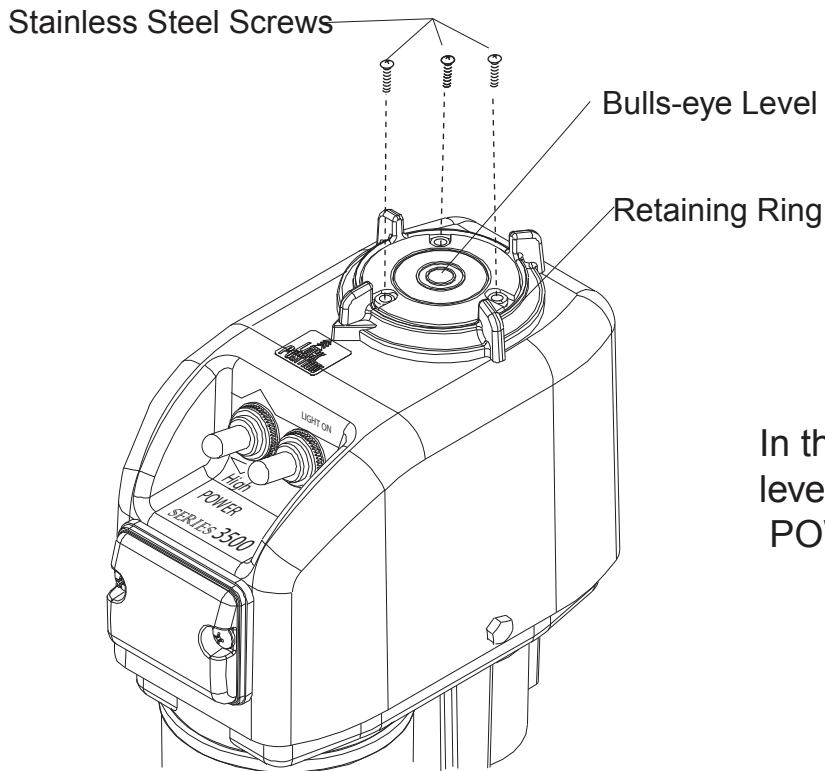

In the future, you can do all your leveling by using your HIGH POWER JACK built-in level.

# HIGH POWER 3,500 BALL SCREW JACK OWNER'S INSTRUCTIONS

## OPERATION (ELECTRIC)

REMEMBER TO KEEP HANDS AND FEET FROM UNDER THE FOOT PLATE WHEN USING HIGH POWER JACK.

When HIGH POWER JACK reaches the end of it's travel (either raising or lowering), the internal limit switch automatically shuts motor off.

Dolly wheels are not recommended.



## Warning

AVOID THE RISK OF INJURY OR DEATH TO YOURSELF AND OTHERS:

- USE THE JACK FOR LIFTING THE TRAVEL TRAILER ONLY.
- NEVER GET BENEATH THE TRAILER WHEN IT IS SUPPORTED BY THE JACK.
- SUPPORT THE VEHICLE WITH THE APPROPRIATE MEANS.

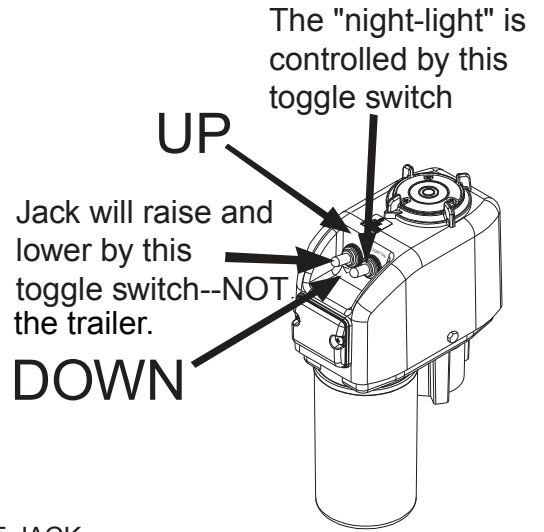

## OPERATION (MANUALLY):

If an electrical failure should occur, the emergency handle may be inserted into the jack post and the jack can be raised or lowered.

(Access can be obtained by twisting level cap off.)

If the powerhead is removed, crank can still be used to raise and lower jack.

!!CAUTION!! If powerhead is removed, it must be synchronized with the jackpost (see page 5).

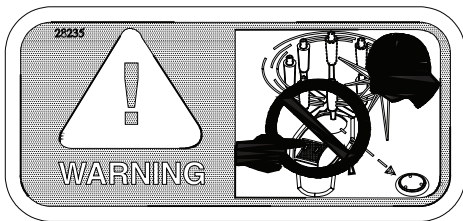
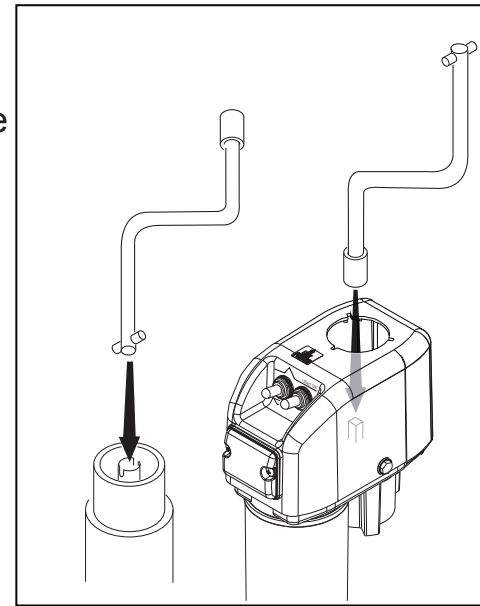

## WARNING!!!

Do not use toggle switch  
crank handle in place.  
Breaking this rule will cause  
serious injury or death.

## !WARNING

Don't risk serious injury or death in a shearing or squeezing accident. Keep body, hands, and feet away.

19989

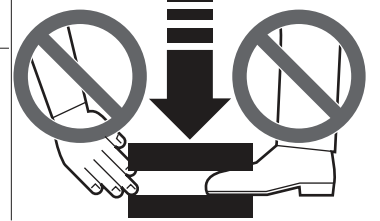

▪ REMEMBER TO KEEP HANDS AND FEET OUT FROM UNDER THE FOOT PLATE WHEN USING THE POWER JACK!!

▪ DOLLY WHEELS ARE NOT RECOMMENDED.

BREAKING THESE RULES WILL CAUSE SERIOUS INJURY OR DEATH.



DIVISION OF BARKER MFG. CO.  
1125 Watkins Road / PO Box 460  
Battle Creek, MI 49016

Phone: 269-965-2371 Fax: 269-965-2389

www.barkermfg.com E-Mail: service@barkermfg.com

© Copyright H&H Engineering 1989

PAGE:	DATE:	FORM #:
3 OF 5	8 AUG 06	27743
REV. LETTER:	ECN#:	APPROVED:
K	13247	

# HIGH-POWER 3,500 BALL SCREW JACK OWNER'S INSTRUCTIONS

## PARTS:

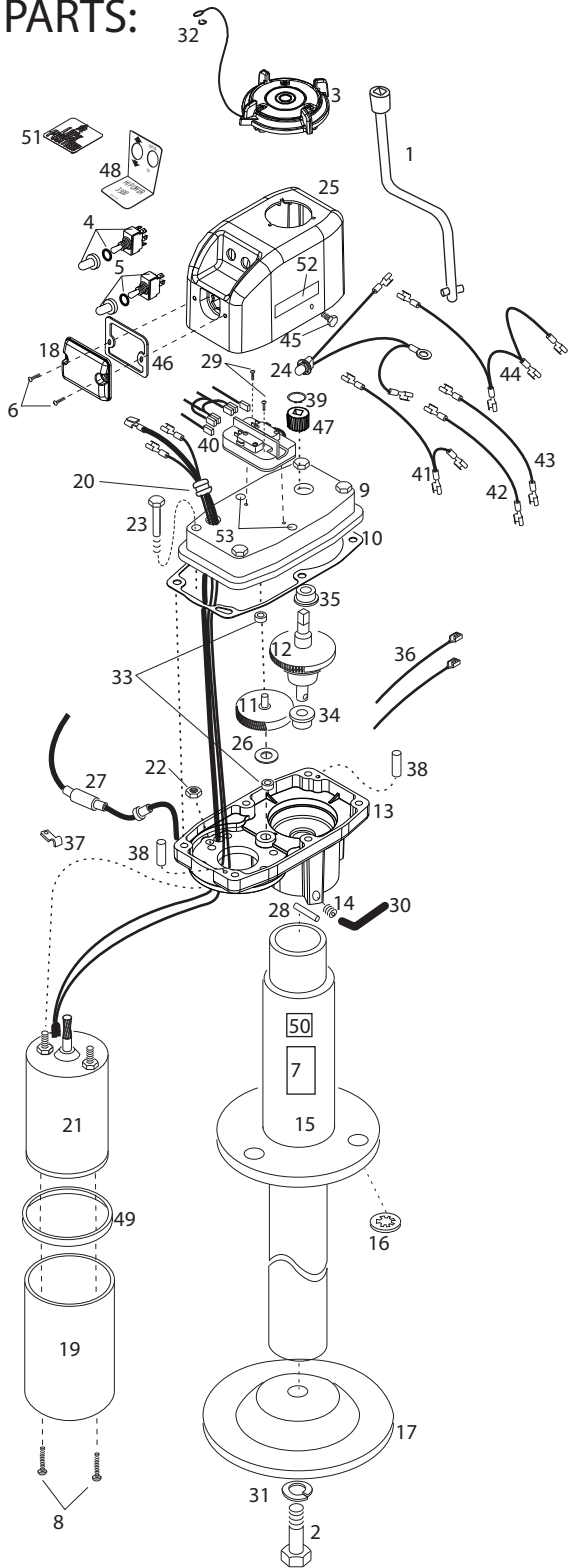

ITEM	PART#	REQ'D	DESCRIPTION
1	28259	1	CRANK HANDLE
2	600-0011	1	HEX BOLT (.50-20 X .75)
3	30331	1	CAP ASS'Y WHITE
4	736-0009	1	TOGGLE SWITCH
5	736-0008	1	TOGGLE SWITCH
6	606-5001	2	#10 X .50 PHILLIPS HEAD SCREW
7	12393	1	SYNCHRONIZE LABEL
8	603-5016	2	#10-32 X .75" PHILLIPS SCREW
9	32152	1	COVER, FINISHED WHITE
10	29306	1	GASKET
11	28207	1	DRIVE GEAR ASSEMBLY
12	28917	1	OUTER GEAR ASSEMBLY
13	30783	1	BASE FINISHED-WHITE
14	608-0006	3	.312-18 X .50" SET SCREW
15	27669	1	POST ASSEMBLY(BLACK- Ø2.25)
16	619-0003	3	INTERNAL TOOTH LOCKWASHER
17	21349	1	BASE H.T. (BLACK)
18	27262	1	LENS
19	27344	1	MOTOR SLEEVE (WHITE)
20	26236	1	RUBBER GROMMET
21	17414	1	MOTOR
22	611-2100	2	HEX LOCK NUT
23	605-0012	4	SCREW
24	27253	1	LAMP WIRE ASSEMBLY
25	27338	1	PLASTIC COVER (WHITE)
26	80208	1	WASHER, SPACER
27	29880	1	CONNECTOR/FUSE HOLDER ASSEMBLY
28	623-1216	1	GROOVE PIN
29	606-0009	2	#10 X .38 SCREW (LIMIT SWITCH)
30	636-0000	1	HEX KEY
31	618-1002	1	LOCKWASHER (.50")
32	634-0028	1	RETAINING RING
33	80501	2	BUSHING
34	645-0024	1	FLANGE BUSHING
35	641-0009	1	BUSHING
36	16392	2	CABLE TIE (BLACK)
37	17808	1	WIRE CLAMP
38	621-0004	2	Ø.13" X .75 DOWEL
39	634-0023	1	RETAINER RING
40	16161	1	LIMIT SWITCH ASSEMBLY
41	27257	1	BLACK WIRE ASSEMBLY
42	27256	1	WHITE WIRE ASSEMBLY
43	27254	1	BLUE WIRE ASSEMBLY
44	27252	1	GREEN WIRE ASSEMBLY
45	606-0010	2	#10-16 X .75 TEK SCREW (ZINC PLATED)
46	30313	1	LENS GASKET
47	27277	1	POT/REED DRIVE GEAR
48	27741	1	COVER LABEL
49	27274	1	MOTOR SEAL
50	24047	1	WARNING LABEL
51	30683	1	LOCK INDICATOR LABEL
52	27848	2	SIDE LABEL
53	16434	2	HOLE PLUG

# barker

1125 Watkins Road / PO Box 460  
 Battle Creek, MI 49016  
 Phone: 269-965-2371 Fax: 269-965-2389  
 www.barkermfg.com E-Mail: service@barkermfg.com

© Copyright H&H Engineering 1989

PAGE:	DATE:	FORM #:
4 OF 5	7 JUL 10	27743
REVISION LETTER:	ECN#:	APPROVED:
O	14239	

# HIGH-POWER 3,500 BALL SCREW JACK OWNER'S INSTRUCTIONS

## SYNCHRONIZATION INSTRUCTIONS:

Powerhead must be synchronized with the jack post:

1. Use the crank to fully retract post.
2. Crank jackpost one turn in opposite direction.
3. ground powerhead to jackpost or trailer frame.
4. Toggle switch down as if lowering the trailer or retracting the post. Continue to hold switch down until motor stops running (as if jackpost is retracted all the way).
5. Install powerhead and tighten (3)set screws.

## STRAP ATTACHMENT

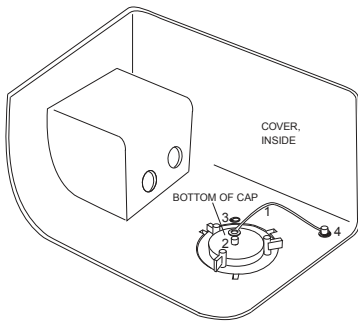

1. Press strap (1) onto the stud (2) at the bottom of the cap.
2. Press the retaining ring (3) on stud (2) snug it down against the strap (1).
3. Repeat this process (4) on the stud found on the inside of the cover.

THIS WILL SECURE YOUR CAP

## SCHEMATIC WIRING DIAGRAM

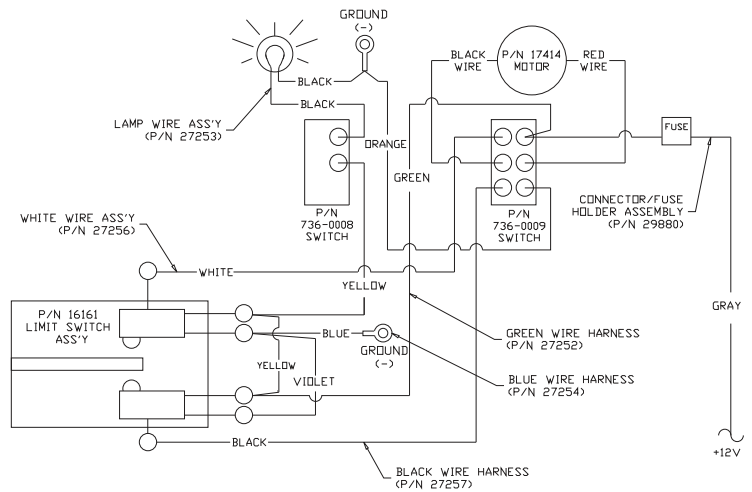

## MAINTENANCE:

Once a year, the powerhead should be removed and a liberal amount of grease (preferably a grease with high melting point) applied directly to the coupling on which the drive pin rests. DO NOT POUR OIL into top of the jack post.

Once a year, the housing cover should be removed and the gears inspected for proper lubrication. Remove 4 screws and tap around edge of housing to free cover. DO NOT insert screw driver blade! (This may damage mating surfaces.) Before replacing cover, clean mating surfaces. If lubrication is needed, use Lubriplate GR-132 grease or equivalent.